



Hand dryer V-JET NOFER Triblade white color

Description

- height-end hand dryer. Operation with height velocity air streams without using hot air distributed in two injection lines.
- height performance. Consumption up to 85% lower than other conventional dryers.
- Microban® antibacterial protection, included in the plastic during manufacture.
- ZeroSmell® gel CK1 odor neutralizing system and optional HEPA filter.
- With water tank and air filter.
- Supplied with a cleaning brush to prevent or solve problems of clogging caused by dirt.
- Suitable for communities and places of very height frequency of use.
- Robust, vandal resistant and safe for being built without sharp edges or other dangerous elements.
- Conforms to European safety directives (CE).

Suggested text for prescription

NOFER hand dryer, by injected air activated by sensor, motor power 1760 W without using hot air. White ABS casing. Dimensions: 617 height x 300 width x 194 depth (mm).

Components

- height-impact ABS outer housing.
- height-impact ABS water tank and air filter.
- With safety thermal limiter and automatic vandalism shutdown.
- Microban® antibacterial protection, included in the plastic during manufacturing.
- ZeroSmell® gel CK1 odor neutralizing system and optional HEPA filter.
- Cleaning brush to prevent or solve problems caused by dirt blockages.

Operation

Place your hands in the inner channel of the device, without moving them.

Cleaning

Cleaning with a cotton cloth slightly moistened in a soapy solution is recommended. Then dry.

Technical characteristics

Material: ABS

Acabado: Blanco

Espesor: 3 mm

Tª salida del aire: a una Tª ambiente de 20°C

Tipo motor: 2 motores de tipo universal

Motor velocidad: 30000 r.p.m.

Velocidad del aire: 340 km/h

Caudal del aire: 4650 l/min

Potencia total: 1760 W

Potencia del motor: 1760 W

Voltaje/Frecuencia: 220-240 V - 50/60 Hz.

Disponible versión de 110/120 V~ (consultar)

Aislamiento eléctrico: Clase II

Consumo: máximo de 8 A

Nivel sonoro a 2 metros: 75 dBA

Índice de protección contra proyecciones: IPX1

Dimensiones: 617 alto x 300 ancho x 194 fondo (mm)

Peso neto total: 9,55 kg

Tiempo de secado estimado: 6-8 segundos

Images



Dos líneas de inyección



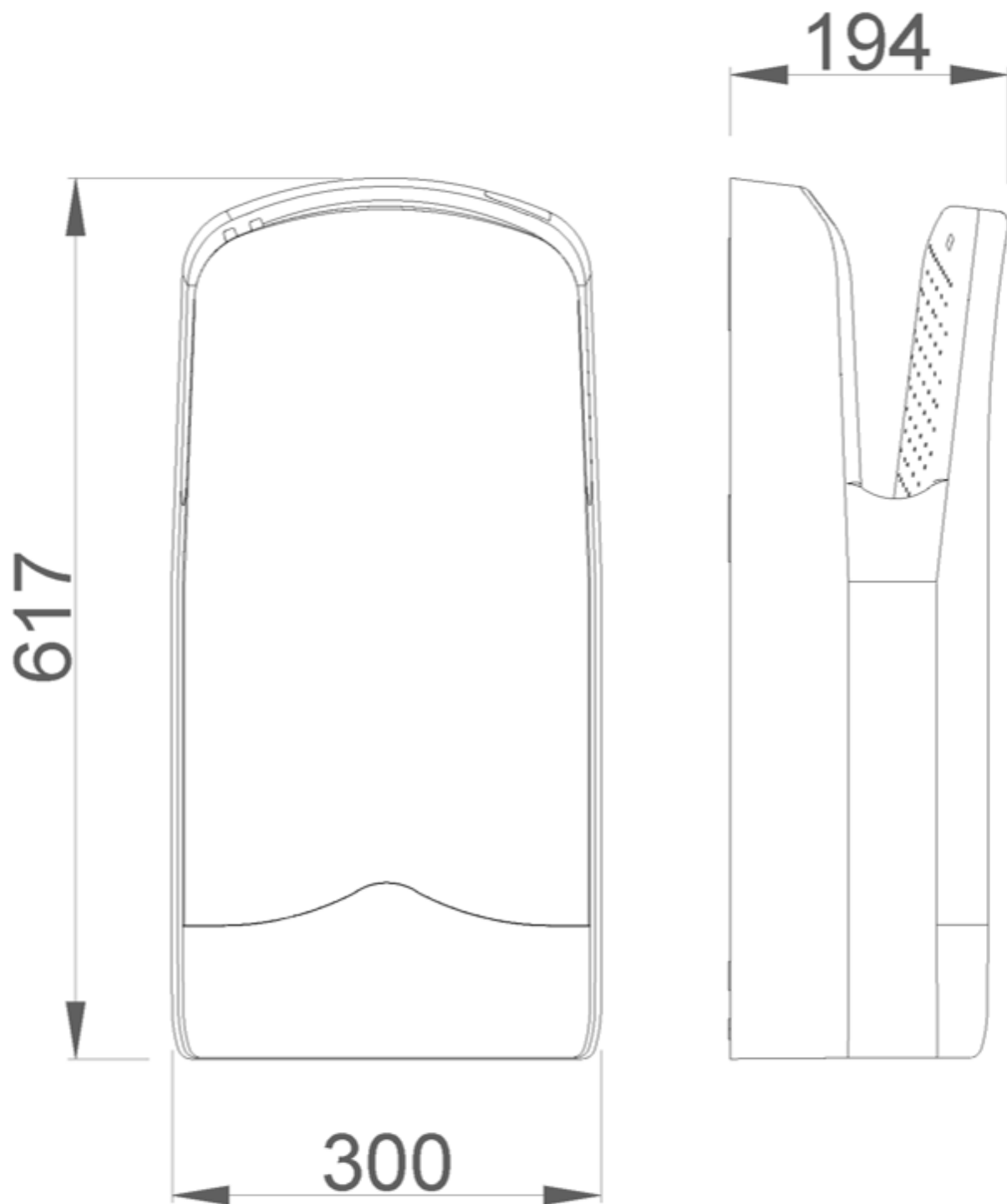

Installation recommendations

En zonas de alta frecuencia de uso, se recomienda instalar un secamanos para cada lavamanos. En zonas con baja frecuencia de uso se recomienda un secamanos por cada dos lavamanos o dos secamanos por cada tres lavamanos. A continuación se muestran las medidas recomendadas para la instalación, tanto en caso de baño standard como adaptado.

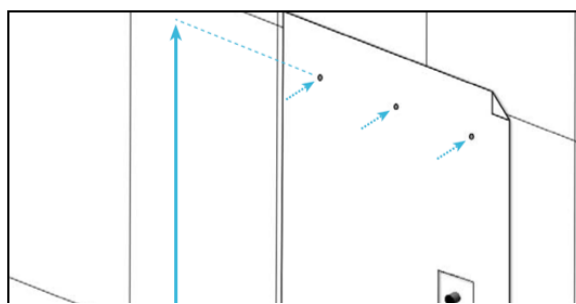

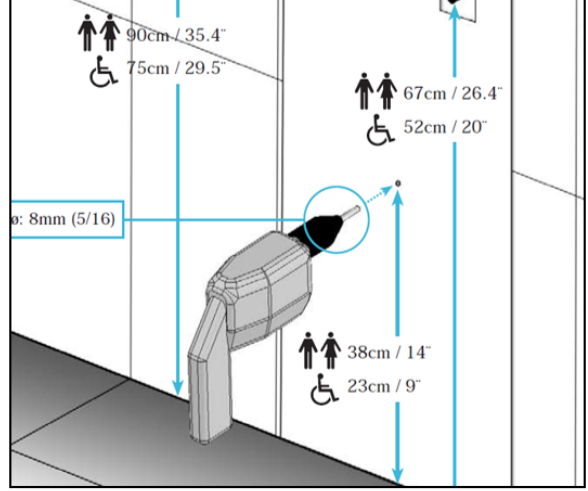
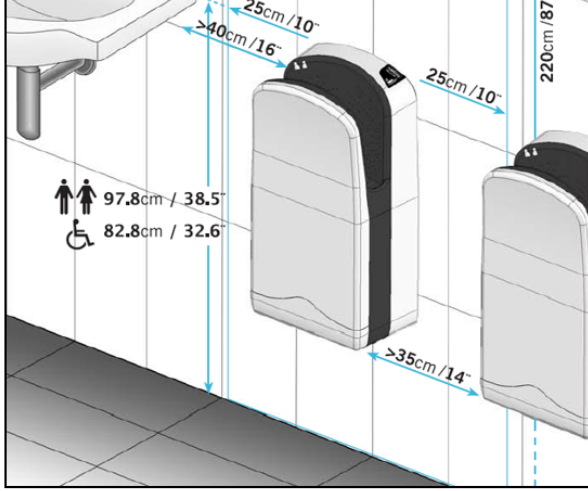

Ctra. Laureà Miró, 385-387
08980 | Sant Feliu de Llobregat,
Barcelona - Spain
T. +34 934 742 423
F. +34 934 743 548
nofer@nofer.com
www.nofer.com

RELATED
PRODUCTS



01305.AB



01305.AS



01305.BD

These specifications may be modified and/or amended due to manufacturing requirements.

